

EW-SFP-GE-SD1310

1.25Gbps SFP Optical Transceiver 20KM DDM

EWIND



- SFP package with LC connector;
- 1310nm FP Laser and PIN photo detector;
- Up to 20km transmission on 9/125 um SMF;
- +3.3V single power supply;
- LVPECL compatible data input/output interface;
- Low EMI and excellent ESD protection;
- laser safety standard IEC-60825 compliant;
- Compatible with RoHS;
- Digital Diagnostic SFF-8472 compliant;
- Signal Ground Isolated to Case.

RoHS **FC** **CE**

1: APPLICATION

- 1.25 Gb/s 1000Base-LX Ethernet;
- 1.06 Gb/s Fiber Channel ;

2: TECHNICAL SPECIFICATION

Parameter	Symbol	Minimum	Typical	Maximum	Units
Absolute Maximum Ratings					
Supply Voltage	Vcc	0	-	+3.6	V
Operating Relative Humidity	RH	5	-	95	%
Operation Environment					
Supply Voltage	Vcc	3.15	3.3	3.45	V
Operating Temperature	Tc	0		+70	
Power Dissipation				1	W
Data Rate			1.25		Gbps
Optical Characteristics					
Transmitter Section					
Center Wavelength	λ_o	1260	1310	1360	nm
Spectral width (RMS)	$\Delta\lambda$	-	-	4	nm

Average Output Power	Po	-9	-	-3	dBm
Extinction Ratio	Er	8	-		dB
Rise/Fall Time(20%~80%)	Tr/Tf			300	ps
Total jitter	Tj			0.43	UI
Optical Eye Diagram	IEEE 802.3z and ANSI Fibre Channel Compatible				
Receiver Section					
Center Wavelength	λ_o	1260		1620	nm
Receiver Sensitivity	Rsen			-22	dBm
Receiver Overload	Rov	-3			dBm
Return Loss		12			dB
LOS Assert	LOSA	-36			dBm
LOS Dessert	LOSD			-23	dBm
LOS Hysteresis		0.5		5	
Electrical Characteristics					
Transmitter Section					
Input Differential Impedence	Zin	90	100	110	Ohm
Data Input Swing Differential	Vin	500		2400	mV
TX Disable	Disable		2.0	Vcc	V
	Enable		0	0.8	V
TX Fault	Assert		2.0	Vcc	V
	Deassert		0	0.8	V
Receiver Section					
Output differential impedance	Zout	-	100	-	Ohm
Data Input Swing Differential	Vout	370	-	2000	mV
Rx_LOS	Assert	-	2.0	-	Vcc
	Deassert	-	0	-	0.8

Add.	Field Size (Bytes)	Name of Field	HEX	Description
EEPROM INFORMATION (A0)				
0	1	Identifier	03	SFP
1	1	Ext. Identifier	04	MOD4
2	1	Connector	07	LC
3-10	8	Transceiver	00 00 00 02 12 00 0D 01	Transmitter Code
11	1	Encoding	01	8B10B
12	1	BR, nominal	0D	1250M bps
13	1	Reserved	00	
14	1	Length (9um)-km	14	20km
15	1	Length (9um)	64/C8/FF	
16	1	Length (50um)	00	
17	1	Length (62.5um)	00	
18	1	Length (copper)	00	
19	1	Reserved	00	
20-35	16	Vendor name	57 49 4E 54 4F 50 20 20 20 20 20 20 20 20 20 20	EWIND
36	1	Reserved	00	
37-39	3	Vendor OUI	00 00 00	
40-55	16	Vendor PN	xx xx xx xx xx xx xx xx xx xx xx xx xx xx xx xx	ASC II
56-59	4	Vendor rev	31 2E 30 20	V1.0
60-61	2	Wavelength	05 1E	1310nm
62	1	Reserved	00	

63	1	CC BASE	XX	Check sum of byte 0~62
64-65	2	Options	00 1A	LOS, TX_DISABLE, TX_FAULT
66	1	BR, max	32	50%
67	1	BR, min	32	50%
68-83	16	Vendor SN	00 00 00 00 00 00 00 00 00 00 00 00 00 00 00 00	Unspecified
84-91	8	Vendor date code	XX XX XX 20	Year, Month, Day
92-94	3	Reserved	00	
95	1	CC_EXT	XX	Check sum of byte 64~94
96-255	160	Vendor specific		

Parameter	Range	Accuracy	Unit	Calibration
Diagnostics				
Temperature	0 ~ 70	±5	°C	Internal
Voltage	3.15 ~ 3.45	0.1	V	Internal
Bias Current	10 ~ 80	±2	mA	Internal
Tx Power	-9 ~ -3	±2	dBm	Internal
Rx Power	-26~-3	±3	dBm	Internal

Pins	Name	Description	NOTE
Pin Description			
1	VeeT	Transmitter Ground	-

2	Tx Fault	Transmitter Fault Indication	1
3	Tx Disable	Transmitter Disable	2
4	MOD DEF2	Module Definition 2	3
5	MOD DEF1	Module Definition 1	3
6	MOD DEF0	Module Definition 0	3
7	Rate Select	Not Connected	-
8	LOS	Loss of Signal	4
9	VeeR	Receiver Ground	-
10	VeeR	Receiver Ground	-
11	VeeR	Receiver Ground	-
12	RD-	Inv. Received Data Output	5
13	RD+	IReceived Data Output	5
14	VeeR	Receiver Ground	-
15	VccR	Receiver Power	-
16	VccT	Transmitter Power	-
17	VeeT	Transmitter Ground	-
18	TD+	Transmit Data Input	6
19	TD-	Inv. Transmit Data Input	6
20	VeeT	Transmitter Ground	-

Notes:

1. TX Fault is an open collector output, which should be pulled up with a 4.7k~10k Ω resistor on the host board to a voltage between 2.0V and Vcc+0.3V. Logic 0 indicates normal operation; logic 1 indicates a laser fault of some kind. In the low state, the output will be pulled to less than 0.8V.
2. TX Disable is an input that is used to shut down the transmitter optical output. It is pulled up within the module with a 4.7k~10k Ω resistor. Its states are:
Low (0~0.8V): Transmitter on
(>0.8V, <2.0V): Undefined
High (2.0~3.465V): Transmitter Disabled
Open: Transmitter Disabled
3. MOD-DEF 0,1,2 are the module definition pins. They should be pulled up with a 4.7k~10k Ω resistor on the host board. The pull-up voltage shall be VccT or VccR.

- MOD-DEF 0 is grounded by the module to indicate that the module is present
- MOD-DEF 1 is the clock line of two wire serial interface for serial ID
- MOD-DEF 2 is the data line of two wire serial interface for serial ID
- 4. LOS is an open collector output, which should be pulled up with a 4.7k~10kΩ resistor on the host board to a voltage between 2.0V and Vcc+0.3V. Logic 0 indicates normal operation; logic 1 indicates loss of signal. In the low state, the output will be pulled to less than 0.8V.
- 5. These are the differential receiver output. They are internally AC-coupled 100Ω differential lines which should be terminated with 100Ω (differential) at the user SERDES.
- 6. These are the differential transmitter inputs. They are AC-coupled, differential lines with 100Ω differential termination inside the module.

3: Recommended Application Circuit

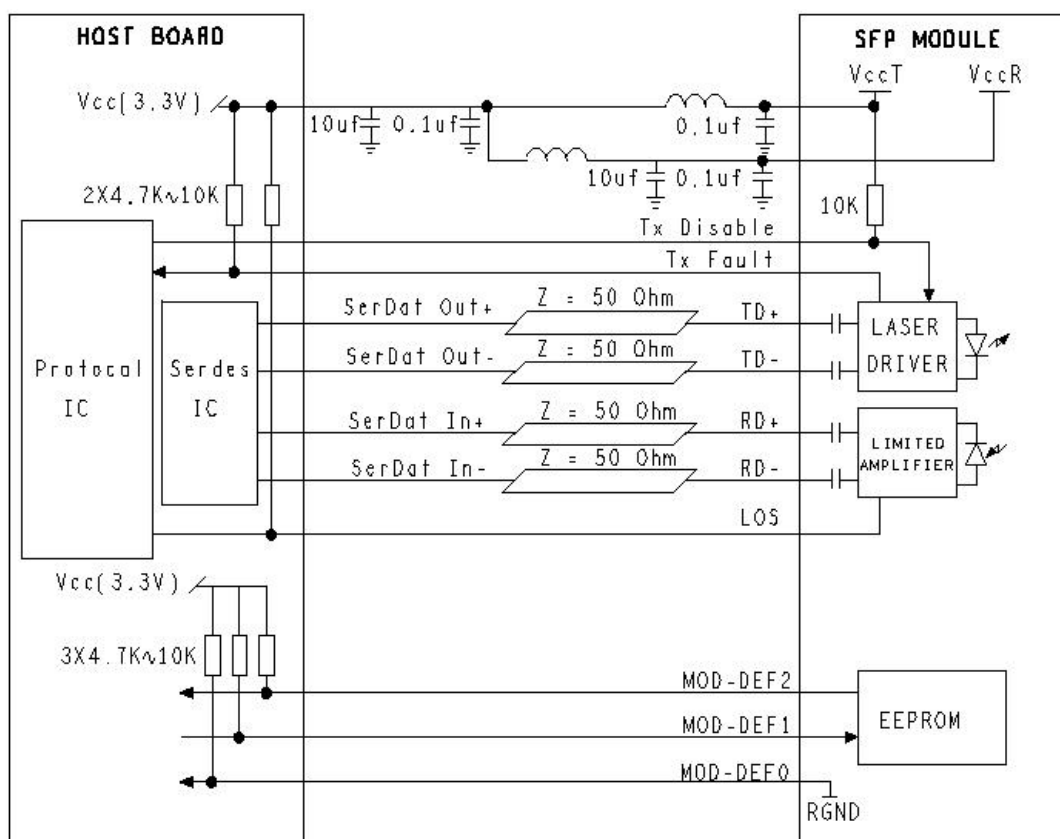

4: Outline drawing (mm)

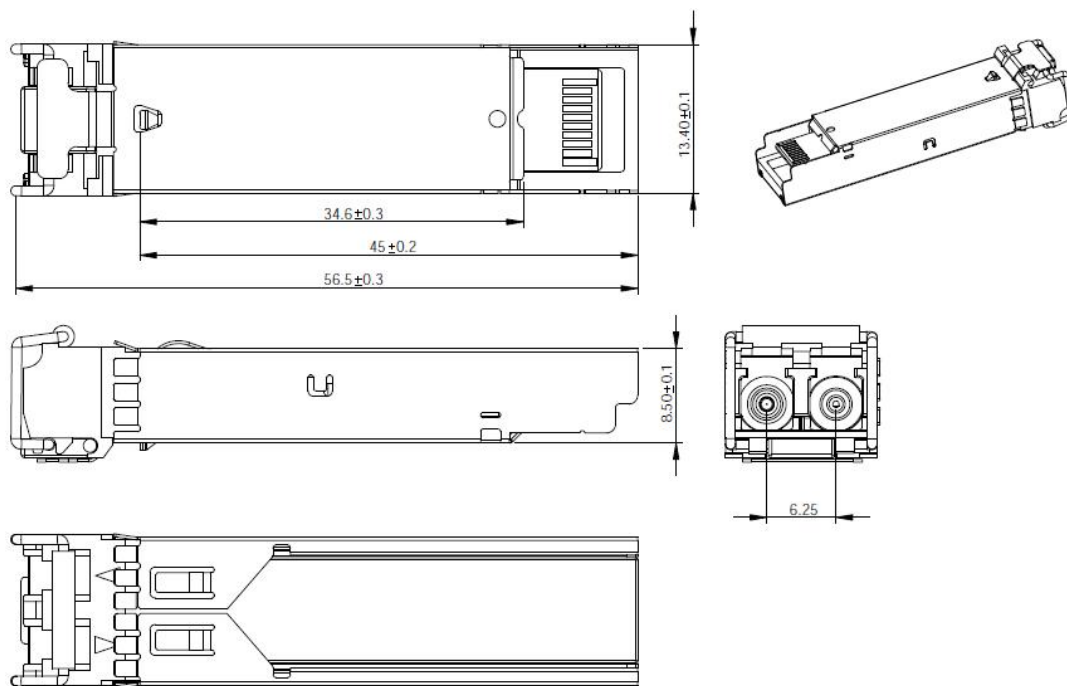

5: ORDER INFROMATION

Model	Description	Units
EW-SFP-FE-MD850	155M, Multi-mode Dual Fiber, 850nm, 550meter, LC connector;	1PCS
EW-SFP-FE-SD1310	155M, Single-mode Dual Fiber, 1310nm, 20km, LC connector;	1PCS
EW-SFP-GE-MD850	1.25G, Multi-mode Dual Fiber, 850nm, 500meter, LC connector;	1PCS
EW-SFP-GE-SD1310	1.25G, Single-mode Dual Fiber, 1310nm, 20km, LC connector;	1PCS
EW-SFP-GE-T1310	1.25G, Single-mode single Fiber, 20km, LC connector,	1PAIR
EW-SFP-GE-R1550	Tx1310/Rx1550nm : 1310nm is transmitter, 1550nm is receiver.	
EW-SFP-10G-MD850	SFP+, 10G, Multi-mode Dual Fiber, 850nm, 300meter, LC connector;	1PCS
EW-SFP-10G-SD1310	SFP+, 10G, Single-mode Dual Fiber, 1310nm, 10km, LC connector;	1PCS
EW-SFP-GFE	1.25G, SFP port transform to 10/100/1000M * RJ45 port	1PCS